



Meteor-RackTM

Table Mounted Media Rack

INSTALLATION INSTRUCTIONS

Components

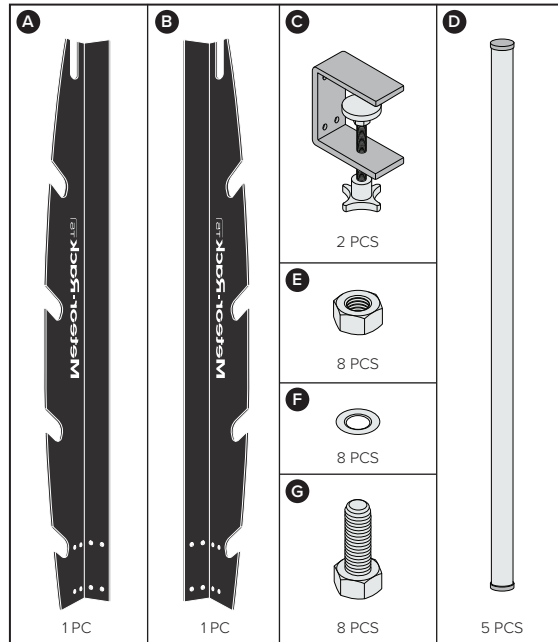

Notes

- **Before installation** account for the potential of the work surface tipping with the concentrated amount of weight at one end of the work surface.
- C-Clamps require full-contact on a flat surface.
- Compatible with tabletops 1/2" to 3" thick (use a spacer if needed).
- **2pcs 7/16" wrenches or sockets are required** (not included). If preferred, use adjustable wrenches.
- It is recommended to load weight from the bottom up.

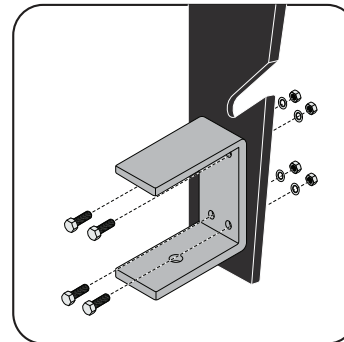
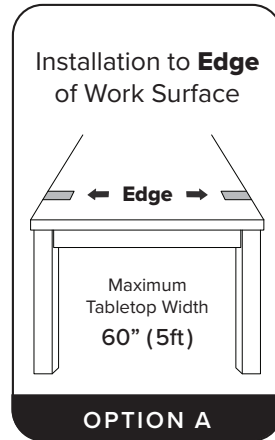

A1 Attach C-Clamp (C) to the outside of an upright (A) with nuts (E), washers (F), and bolts (G).

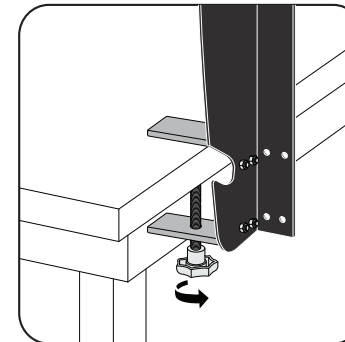

A2 Slide onto **edge** of work surface. Fully-tighten knob screw to secure C-Clamp (C) in position.

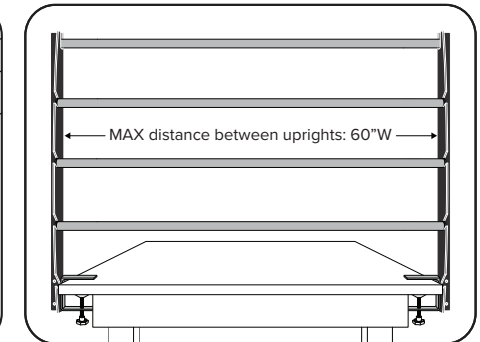

A3 Repeat steps A1 and A2 for the opposite side. Place poles into position, balancing the overhang on each side.

CAUTION Please read all instructions before attempting installation

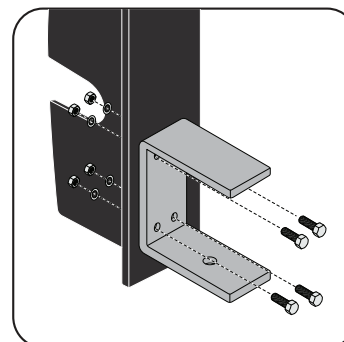
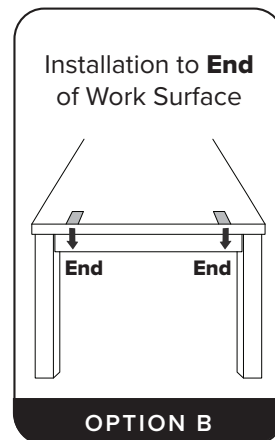

B1 Attach C-Clamp (C) to the back of an upright (A) with nuts (E), washers (F), and bolts (G).

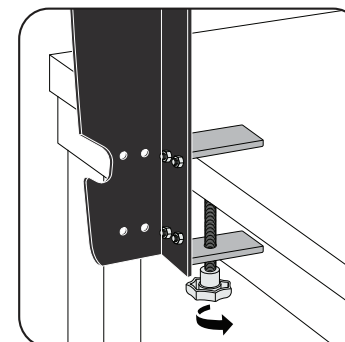

B2 Slide onto **end** of work surface. Fully-tighten knob screw to secure C-Clamp (C) in position.

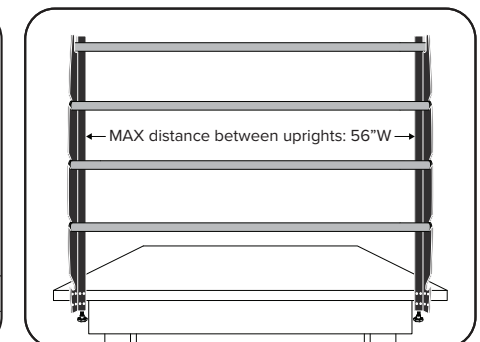

B3 Repeat steps B1 and B2 for the opposite side. Place poles into position, balancing the overhang on each side.